



STANDARD UV SYSTEM

Installation & Maintenance of the Fresh-Aire UV® Standard UV Light Kit for Commercial Air Handler Systems

The Fresh-Aire UV® Standard UV Light Kit is designed for installation into commercial air handling units for the purpose of surface or airborne disinfection using ultraviolet germicidal irradiation. The remotely mounted weather resistant power supply can withstand the wet environment found inside of air handlers or the exposed conditions of outdoor packaged air conditioning systems.

The number and placement of lamps is determined by several factors including coil dimensions and whether surface or airborne disinfection is desired. A Fresh-Aire UV® commercial UV specialist can help configure the best system for your application.

As a general rule, normal output UV lamps are recommended for surface treatment applications. Higher output lamps and power supplies are only recommended for airborne treatment. Both types of systems may be installed in a similar fashion with the same mounting hardware.

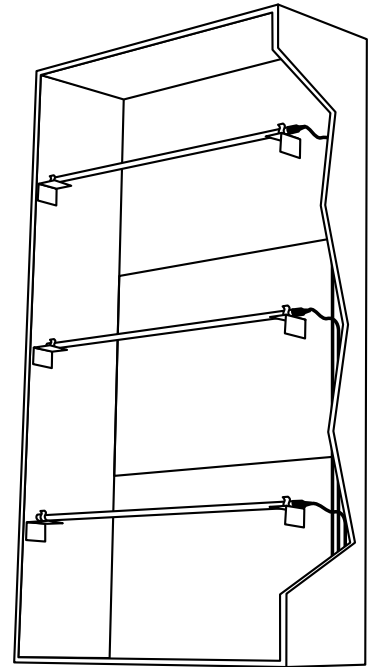

WARNING
 PROTECT EYES FROM UV LIGHT
 TURN OFF UNIT OR DISCONNECT
 BEFORE SERVICING

The Fresh-Aire UV® Standard UV Light Kit comes with L-bracket lamp-clips for easy mounting. Install as is, or with an installer supplied rack.

IMPORTANT!

- Only qualified technicians should install this product*
- Install in accordance with relevant building codes
- Read instructions carefully including safety warnings

*Installation of this product by anyone other than licensed HVAC or electrical contractors voids warranty.

Parts Included

- A** UV Lamp(s) 1 Year
- B** UV Lamp(s) 2 Year
- C** Power Supply(s) 10"*
- D** Power Supply(s) 14"**
- E** Sheet-metal Screws
- F** L-Bracket
- G** Black Nylon Zip-Ties
- H** Sight Glass 1"
- I** Sight Glass 1/2"
- J** Lamp Cable 10'
- K** UV Warning Sticker

Optional Parts

- L** Cable Strain Relief TUV-C-SR1/2, 3/4, 1
- M** Mounting Magnet TUV-C-LBRKT-MG
- N** Cable Extensions TUV-CBL5, 10
- O** 12" Stand-off TUV-C-CMBRKT
- P** Door Interlock Switch TUV-C-INTLCK
- Q** UV Shield TUV-SHIELD32, 46, 60
- R** View Port TUV-C-VP-D

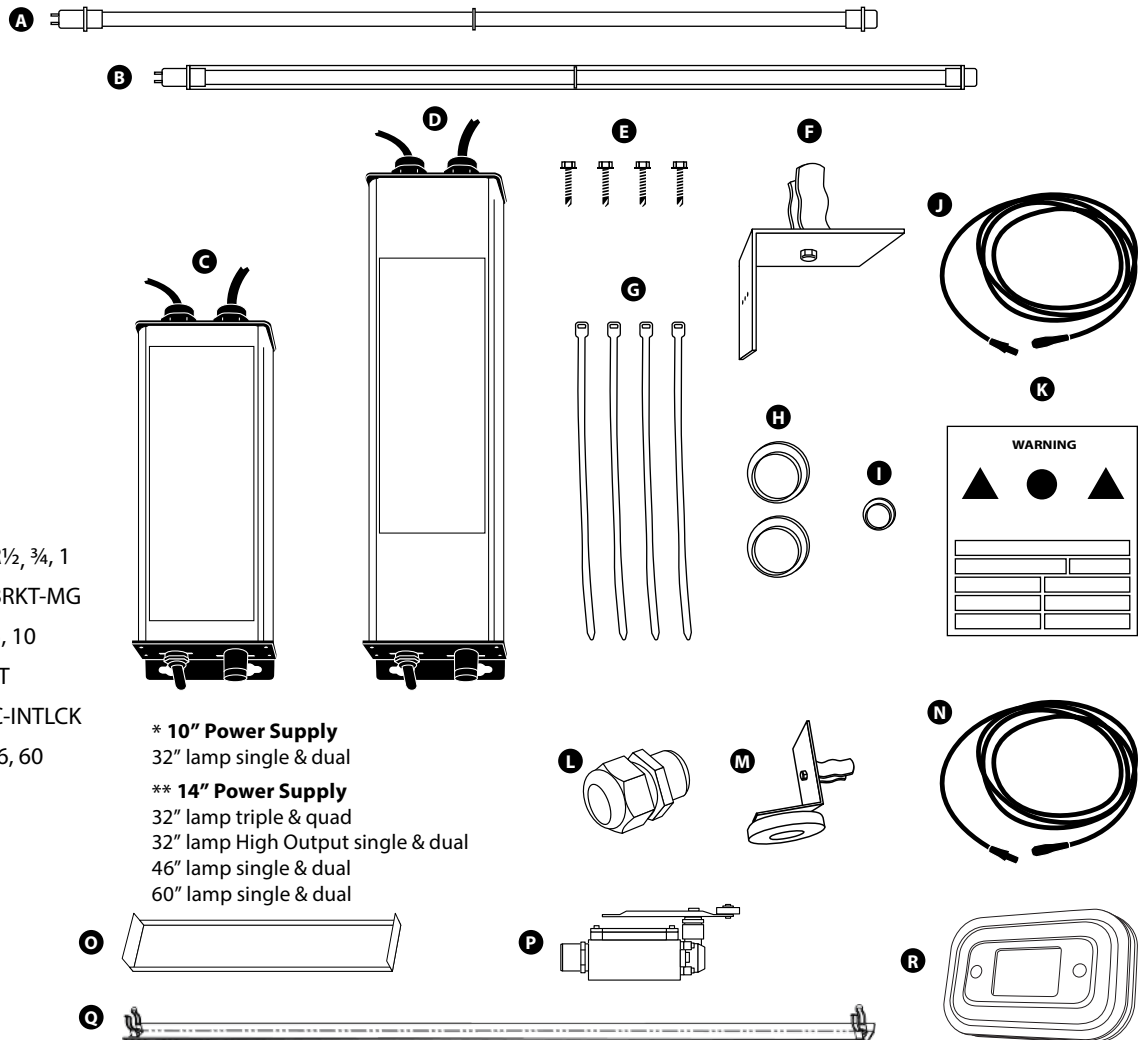

System Configuration

1. Determine the dimensions of the coils or area to be irradiated.
2. Use the following guidelines to estimate the number of lamps needed for proper coverage.

UV Lamp Configuration Guidelines

- Maximum germicidal effectiveness is within an 18" radius from UV lamp center axis
- The optimal distance between UV lamp(s) and the irradiated surface is 12"
- The distance between stacked UV lamps should not exceed 35"
- The distance between end to end UV lamps should not exceed 12"
- The distance of UV lamp ends to the edge of irradiated surface should not exceed 6"

Fresh-Aire UV offers a free system configuration consultation service for commercial projects. Contact Fresh-Aire UV for details.

3. Before attaching the **L-Brackets** for mounting use the **Optimal Irradiation Distance** and **Lamp Spacing** diagrams to confirm that when installed the **Uv Lamps** will be positioned properly.

Lamp Spacing

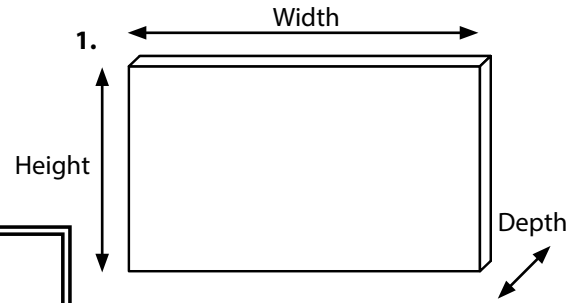
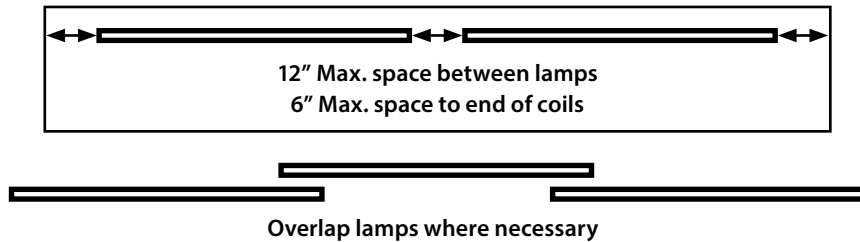

Optimal Irradiation Distance

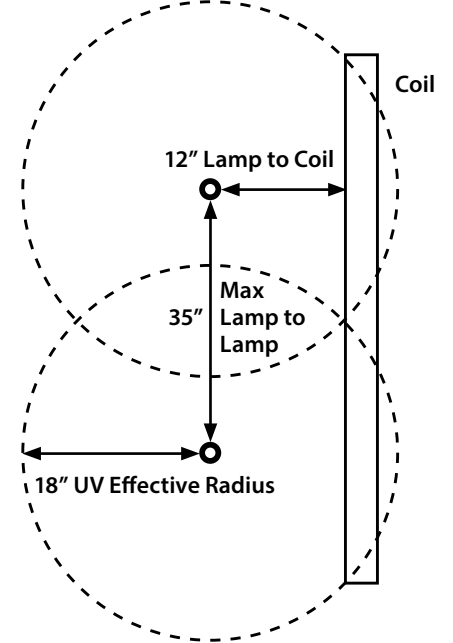

4. UV lamps are mounted into the air handler using the "L" brackets provided, or, use **Optional 12" Stand-offs** to achieve optimal distance to the coils.

Standard UV Spacing

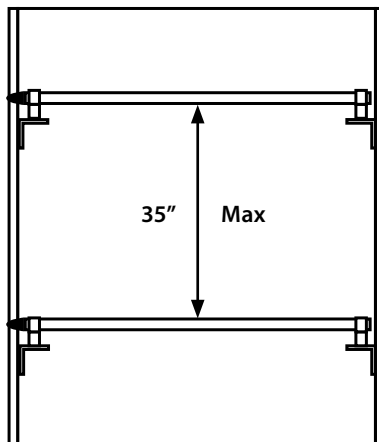

Single UV lamp per EMT piece

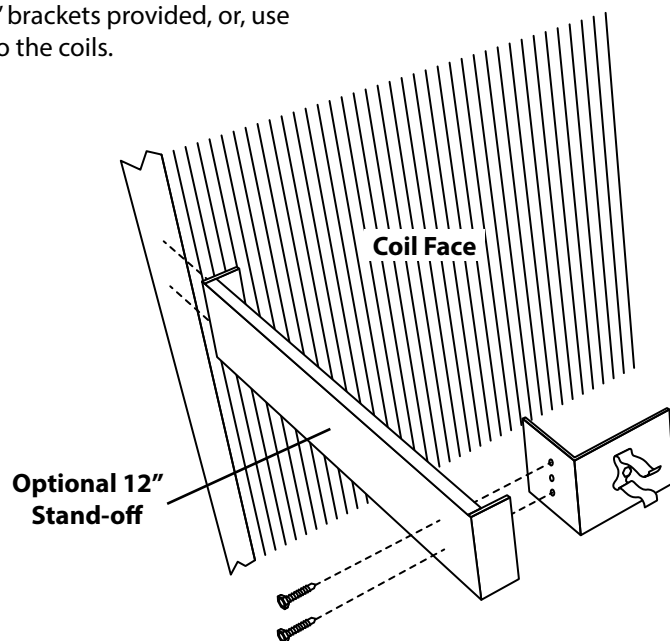

Use Optional 12" Stand-offs to change the distance to the coil

2 Install UV Lamps

Snap **UV Lamps** into the **L-Brackets**. Be sure to clamp to the rubber lamp connector on one end and the ceramic lamp tip on the other end. **DO NOT clamp onto the lamp glass.** Use **Black Nylon Zip-Ties** to secure lamp cables.

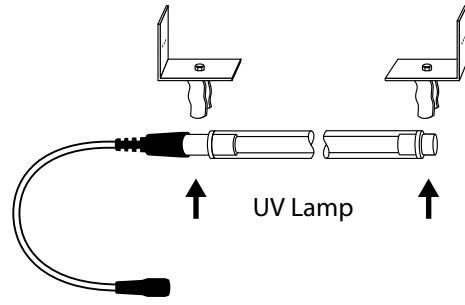

3 Mount Power Supply(s)

Mount the power supply in a location (inside or outside of the HVAC system) that is convenient for access to the main power supply and for connection to the UV lamps. The power supply is weather resistant and is suitable for mounting inside or outside of the air handler. An **Optional Power Supply Panel Mount** (part # TUVCP-P) is available for mounting two or more power supplies.

1. Use the supplied self-taping sheet metal screws to mount the power supply in place through the mounting holes on the sides of the base. It is recommended to use wire boxes, our **Optional 3/4" or 1" Cable Strain Relief**, or other sealing methods in order to pass the power cord and lamp cables into the interior of the air handler for connections.

2. **IMPORTANT! Turn off main power before making electrical connections.** Refer to the **Electrical Diagram** for proper connection of the power supply to the main power.

Electrical Diagram

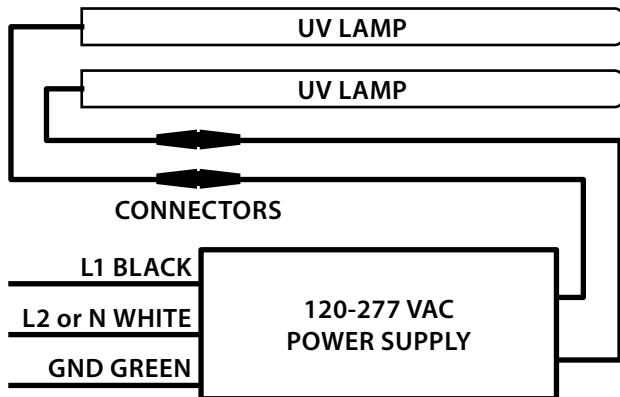

IMPORTANT! Connect in accordance with all state and local electrical and building codes. Proper voltage is automatically selected by the unit between 120–277 VAC Single Phase 50/60 hz. **IMPORTANT! An external power suppressor is suggested if power surges occur often.**

3. Use of **Optional Door Interlock Switches** is highly recommended to prevent accidental exposure to UV Light. Interlock switches are mounted on the access panels and doors so the UV lights turn off when the entryway is opened.

4. Use the **Optional UV Output Monitor**, to monitor and alert maintenance personnel when UV lamps should be replaced.

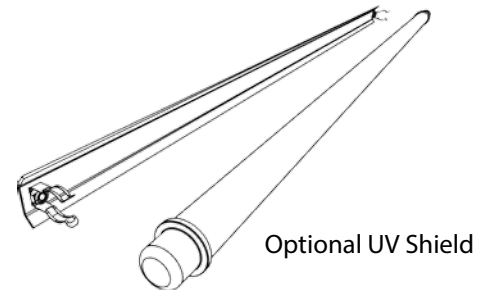

Use **Optional UV Shields** when there are materials (such as older brittle insulation, filter media etc.) in the air handler which may be damaged by UVC exposure. Snap the shield onto the lamp ends, rotate into position .

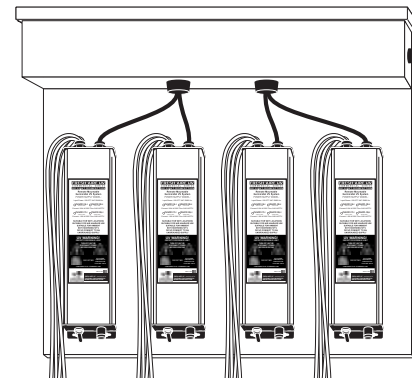

Optional Power Supply Panel Mount

4 Connect Lamps & Cables

Arrange cables as needed for installation. If necessary use the **Optional 3/4" or 1" Cable Strain Relief** to pass cables through cabinets, air system walls, etc. **Optional 5', 10', 20' Cable Extensions** are available for longer runs. When UV lamps, power supplies, and cables are in place join the lamp and power supply cables by aligning the electrical pins and flanges on the rubber connectors and pushing them firmly together.

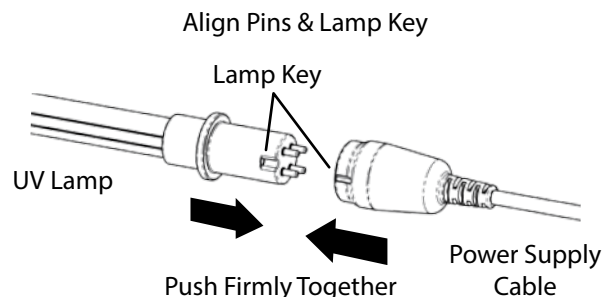

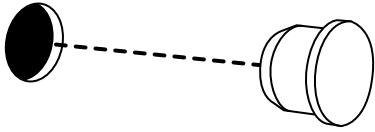

5 Sight Glass Installation

1. The sight glass allows safe viewing of the UV light system when in operation. Find a suitable location such as a door to the HVAC system for the sight glass.
2. Drill a 1" hole and press the base of the sight glass through it.

6 Power-up System

Caution: UV-C light that can cause **Serious Eye Burns** and **Temporary Blindness**, Ensure all access panels have been replaced and doors closed before powering-up the system.

Turn on the main power then switch on the UV light power supply(s). Use the sight glass to confirm that the UV Lamp(s) is operating.

7 UV System Maintenance

Periodically wipe the UV lamps with a clean cloth or alcohol swab to remove any accumulated dust or dirt. This should be performed at least every 6-9 months or during routine maintenance intervals. Fouling could occur if lamps are installed under chilled water lines. Wipe clean or install optional shield.

8 UV Lamp Replacement

Fresh-Aire UV® lamps are rated for either one or two years germicidal effectiveness. The lamps will continue to glow after they have passed their rated life span but their germ-killing effectiveness diminishes with time so they must be replaced on schedule for the system to function properly.

Contact your local dealer for replacement lamps.

Part# TUVCL-132	1 Year Effective Lamp Life
Part# TUVCL-132HO	High Output - 1 Year Effective Lamp Life
Part# TUVCL-232	2 Year Effective Lamp Life
Part# TUVCL-146	46" 1 Year Effective Lamp Life
Part# TUVCL-246	46" 2 Year Effective Lamp Life
Part# TUVCL-160	60" 1 Year Effective Lamp Life
Part# TUVCL-260	60" 2 Year Effective Lamp Life

Important! Use only Fresh-Aire UV® replacement lamps. Use of replacement lamps from other manufacturers voids the warranty.

9 Trouble Shooting

Problem	Solution
UV Lamp(s) Not Lighting	<ol style="list-style-type: none"> 1. Check that power is applied. 2. Check that the unit is turned ON. 3. Ensure the remote lamp cables are properly connected. 4. Check the fuse. Replace only with same size and type. 5. Reset power switch on power supply (off then on). 6. Install New UV Lamp(s). 7. Consult Factory.
UV Lamp(s) Flickering	<ol style="list-style-type: none"> 1. UV Lamp(s) have reached end of effective service life. Install new lamp(s) of same type. 2. If unit is new, check remote cables to ensure they are properly connected. 3. Reset power switch on power supply (off then on). 4. If new lamps still flicker, consult factory.
UV Lamps Have burned Out Prematurely	<ol style="list-style-type: none"> 1. Consult Factory.
Power Supply Will Not Light UV Lamps even after new lamps are installed	<ol style="list-style-type: none"> 1. Consult Factory. 2. External power suppressor may be needed if power surges occur.

Fresh-Aire UV® Commercial Series

Fresh-Aire UV® lights save energy by reducing microbial growth inside HVAC systems, lower maintenance costs and reduce maintenance workers exposure to chemicals while improving indoor air quality. Our commercial systems are renowned for their quality materials, innovative features, ease of installation, and flexible mounting options. Most feature our advanced multi-voltage water-resistant power supply. All come with the Fresh-Aire UV® Lifetime Warranty on all parts except lamps.

Standard Commercial UV Light System

Standard 32" lamps with L-brackets for easy installation. Choose 32", 46", 60" normal-output or 32" high-output lamps. Combine single, dual, triple, quad lamp configurations to suit any size HVAC installation.

Tubular Rack System

The Fresh-Aire UV® Tubular Rack System offers easy, flexible installation of multi-lamp configurations. The Tubular Rack System is installed using supports made with standard ½" EMT tubing (not included). You can also choose to have custom steel tubing prepared for you by Fresh-Aire UV®. The system includes all the hardware necessary for mounting.

APCO® Rack System

Same as our Modular Rack System with the addition of activated carbon cells for photocatalytic VOC reduction.

Airborne Duct System

Features High-Output lamps for air-steam disinfection. Ideal for hospitals, clean-rooms, and other IAQ priority situations.

Panel Mount System

Installs in hard to reach areas by allowing access to the coil from the outside of the air system.

Tight-Fit Kit™

Low-voltage UV disinfection for PTACs, fan coils, & wall-mount systems.

Fresh-Aire UV® Warranty:

This warranty supersedes and replaces any warranty statements orally made by the Sales Person, Distributor or Dealer or contained in the written instructions or other Brochures or informational documents in relation to this product. This warranty gives you specific legal rights, and you may also have other rights which vary from State to State.

What Does This Warranty Cover? This lifetime limited manufacturer warranty covers any defects or malfunctions in material and workmanship under the normal use and service when operated and maintained in strict accordance with manufacturer's instructions for the Lifetime of the equipment.

How Long Does The Coverage Last? 1) Fresh-Aire Power Supply: For as long as you own the real property where the product is installed. 2) TUVL-1XX and TUVCL-1XX Series Ultraviolet Lamps are warranted for germicidal output for one-year from the date of installation. 3) TUVL-2XX and TUVCL-2XX Series Ultraviolet Lamps are warranted for germicidal output for two (2) years from the date of installation. This warranty is not transferable.

What Will Triatomic Environmental, Inc. Do? Triatomic Environmental, Inc. will replace any defective or malfunctioning part at no charge. You must pay any labor charges and shipping charges of defective product to our warranty department.

What Does This Warranty Not Cover? THIS PRODUCT IS NOT INTENDED TO BE PURCHASED AND INSTALLED BY UNLICENSED HVAC OR ELECTRICAL CONTRACTORS. This warranty does not cover products or parts purchased from any source other than licensed HVAC or electrical contractors. This warranty does not cover parts installed by unlicensed HVAC or electrical contractors. This warranty does not cover parts damaged as a result of misuse, abuse, or any use other than its intended use, accident, acts of god, neglect, or from improper operation, maintenance, installation, modification or adjustments. Triatomic Environmental, Inc. shall have no responsibility for charges incurred by the customer for installation or removal of warranted items.

This warranty does not cover parts or equipment used with the Fresh-Aire that are not manufactured by Triatomic Environmental, Inc.

**This warranty shall be void if UV lamps from manufacturer's other than Triatomic Environmental, Inc. are used with this equipment.

Consequential and incidental damages are not recoverable under this warranty. Manufacturer assumes no liability for any harm, which may occur as a result of the use of the equipment herein and shall not be liable for consequential or any other damages whether or not caused by manufacturer's negligence or resulting from any express or implied warranty or breach thereof. Consequential damages for the purpose of this warranty shall include, but not be limited to, loss of use, income or profit, or loss of or damages to property or injury or death to persons or animals occasioned by or arising out of operation, use, the operation, installation, repair or replacement of the equipment or otherwise. Some states do not allow the exclusion or limitation of incidental or consequential damages, so the above limitation or exclusion may not apply to you.

There are no Warranties which extend beyond the description of the face hereof.

How Do You Get Service? In order to be eligible for service under this warranty you MUST return the warranty registration card included in the packaging within 30 days of installation of the Fresh-Aire product. If something goes wrong with your product, call 800-741-1195 to receive a Return Merchandise Authorization (RMA) and instructions for returning the product to a licensed distributor in your area or the manufacturer.

Once the product is returned, we will inspect your product and contact you within 10 business days of our receipt of the product to give the results of our inspection. If we determine that the product is covered under this warranty, we will ship to you at no additional cost a replacement part. Replacement parts may be refurbished. If we determine that the product is not covered under this warranty, or that this warranty is void, the product will be returned to you COD. There is no charge for inspection.

How Does State Law Apply? This warranty gives you specific legal rights, and you may also have other rights which vary from state to state.



WWW.FRESHAIREUV.COM
sales@freshaireuv.com